

# University Students Race Cars

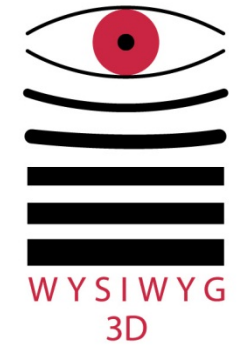

Formula Society of Automotive Engineers (FSAE) is an international student-based project where teams design, construct and compete with a small open-wheeled racing car intended for use in weekend autocross competitions. All research, design and manufacture must be completed within a period of 12 months to prepare for the annual event held by the Society of Automotive Engineers, Australasia. The three-day event scores teams on their design, costing and marketing skills as well as dynamic events of skid pad, acceleration, autocross and endurance.

The underlying concept of the competition is for students to be involved in every aspect of creating a hypothetical company which has been commissioned to design a marketable and profitable formula style car. The competition is designed to challenge and enhance the knowledge and creativity of the students.

Introduced in 2000 to Australia, the competition has grown in strength, development and numbers over the years. The Australasian competition now plays host not only to Australian teams, but has teams coming from New Zealand, Japan, India, Malaysia, Europe and the USA. The emerging engineers from the Formula SAE-A competition are closely followed and sought by the automotive industry for their technical knowledge and practicality that is developed in designing and manufacturing the cars.

So how does a body of student engineers go about designing a race car?

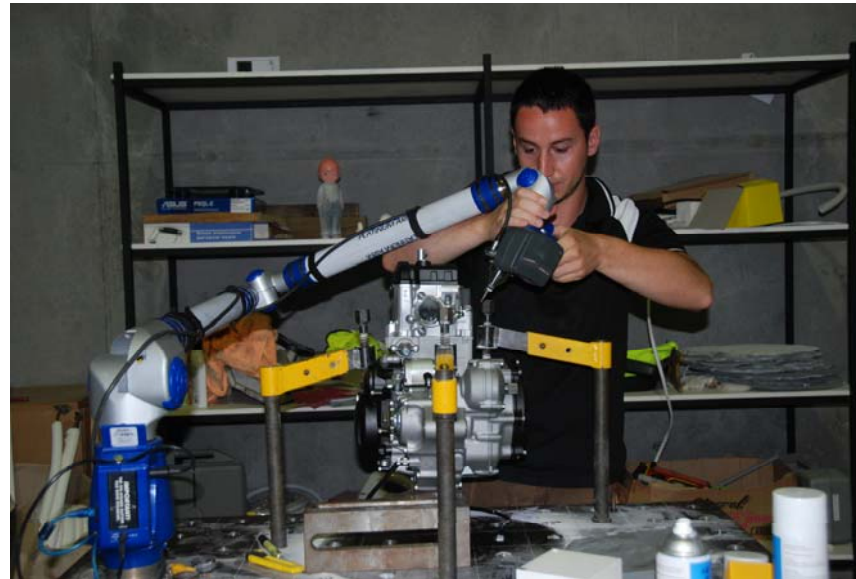

WR450 being scanned.

Engine as installed in Spaceframe Chassis.



# University Students Race Cars

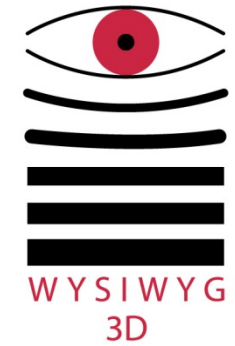

The very first consideration is the power plant. With this selected based upon performance, reliability and power to weight criteria, the next step is to design the chassis around the selected motorbike engine and gearbox! How do you design a chassis to fit an existing motorbike engine? You look for a 3D scanning service provider, to capture the engine and gearbox as a volume and to measure the functional engineering data.

Wysiwyg 3D owner Mr Shane Rolton, a Mechanical Engineer from UTS, is a proud supporter of the Formula and over the last decade has sponsored numerous Student teams, including UTS, Uni Newcastle, Uni of Sydney, Uni of NSW, ADFA, and Monash. By scanning the engine and gearbox assembled, an STL file of varying file size is generated. At the same time all of the functional features such as OEM engine mounting holes, manifold planes, inlet throats, spark plug and shaft centrelines are measured by probe. The students can then import both the STL and the Iges Datums into their Universities CAD packages and design the chassis, suspension and body around the Engine model, knowing that the engine will fit, be able to be serviced and even place the mass at the CG of the real engine. Silly mistakes such as not being able to remove the spark plugs due to a chassis cross member being in the way can be quickly identified and eliminated from the design well before the chassis is even built.

Wysiwyg 3D would like to thank the organising committee of the SAE for all the work behind the scenes and to all students competing in the 2011 FSAE competition the very best of luck, good engineering and most importantly have FUN!

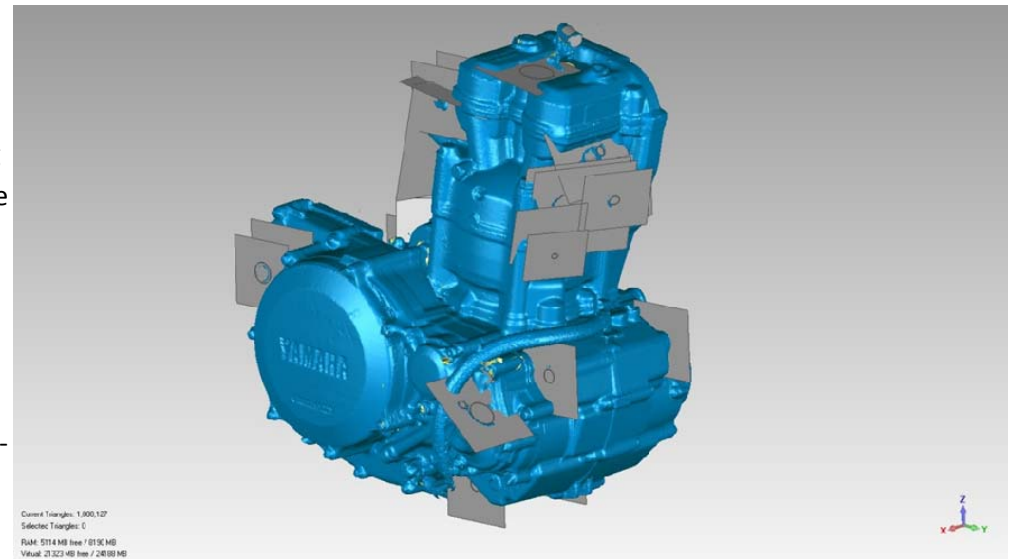

**Resulting Scanned Engine Volume (STL) and Probed Engineering Features (iges)**